

Panel mounted receptacle with TwinCONTACT - Part no. 3590

- screwless spring terminals
- standard flange dimensions
- suitable for through wiring
- 20° inclination
- receptacles optional fitted with auxiliary contact

Technical information

Ampere	32 A
Poles	5 p
Voltage	400V
Earth position	6 h
Hertz	50-60 Hz
Connection technology	Screwless - TwinCONTACT
Contact	standard
Protection type	IP 67

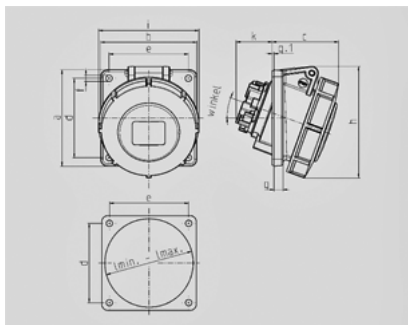

Drawing 1 MB 520	Amp. Poles	16			32		
		3	4	5	3	4	5
Dim. in mm	a	85	85	85	85	85	85
	b	85	85	85	85	85	85
	c	56	59	59	64	64	71
	d	70	70	70	70	70	70
	e	70	70	70	70	70	70
	f	5.5	5.5	5.5	5.5	5.5	5.5
	g	8	8	8	8	8	8
	g-1	2	2	2	2	2	2
	h	87	91	99	103	103	110
	i	78	85	89	103	103	106
	k	32	32	33	44	44	49
	l min.	57	64	70	78	78	78
	l max.	76	76	76	78	78	78
	Terminal for cond. cross section (mm ²) min.-max.	1.5	1.5	1.5	2.5	2.5	2.5
		-4	-4	-4	-6	-6	-6